

REV.	DESCRIPTION	DATE	BY	APP
A	REDRAWN AND REVISED, PUT ON AUTOCAD	6/26/96	PJB	RCW
B	B <sub>1</sub> CONVERTED SIZE E TO D; B <sub>2</sub> ITEM 7 WAS 91151A033; B <sub>3</sub> ADDED NOTE	4/23/02	BJA	RCW
C	C <sub>1</sub> CONVERTED SIZE D TO E; C <sub>2</sub> ADDED NOTE; C <sub>3</sub> ADDED VIEW	8/21/06	RWN	MRS

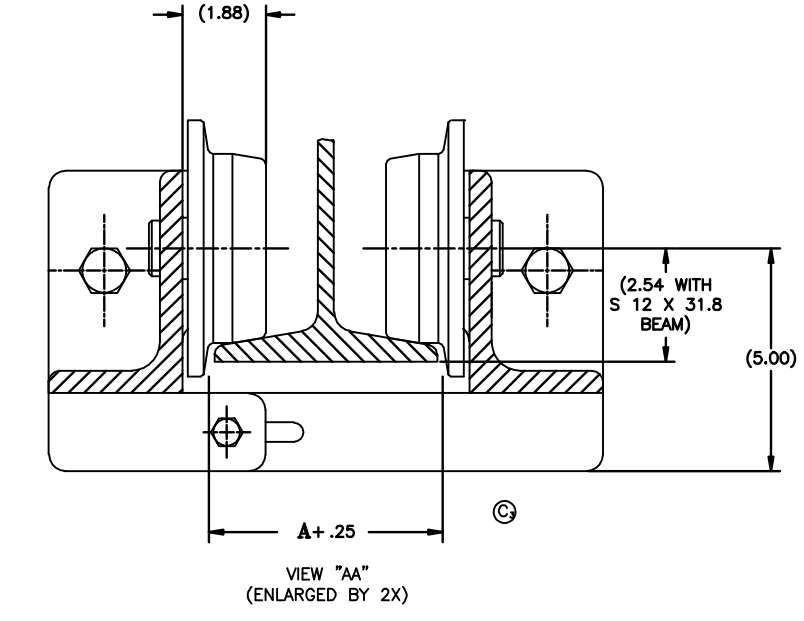
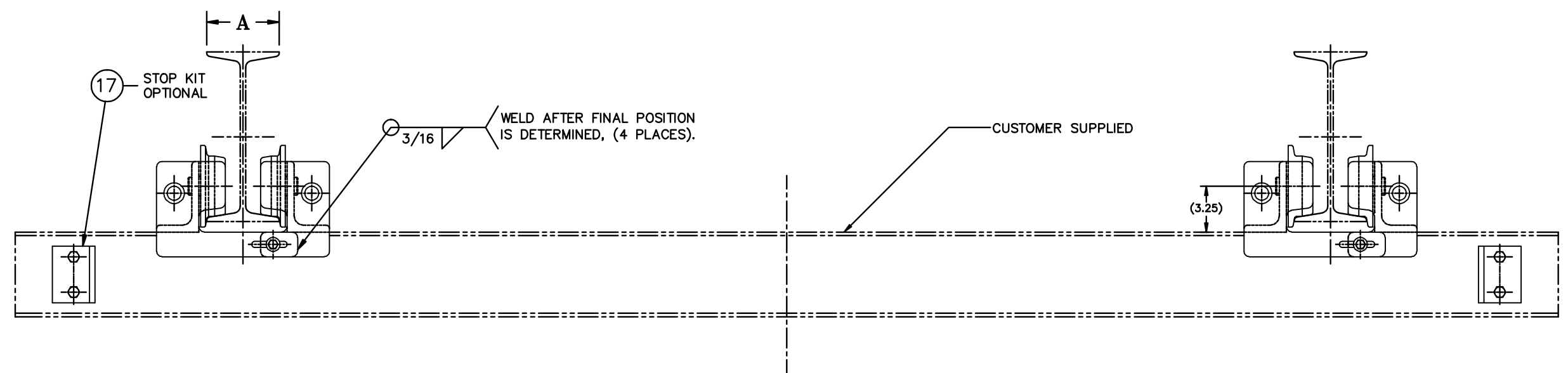
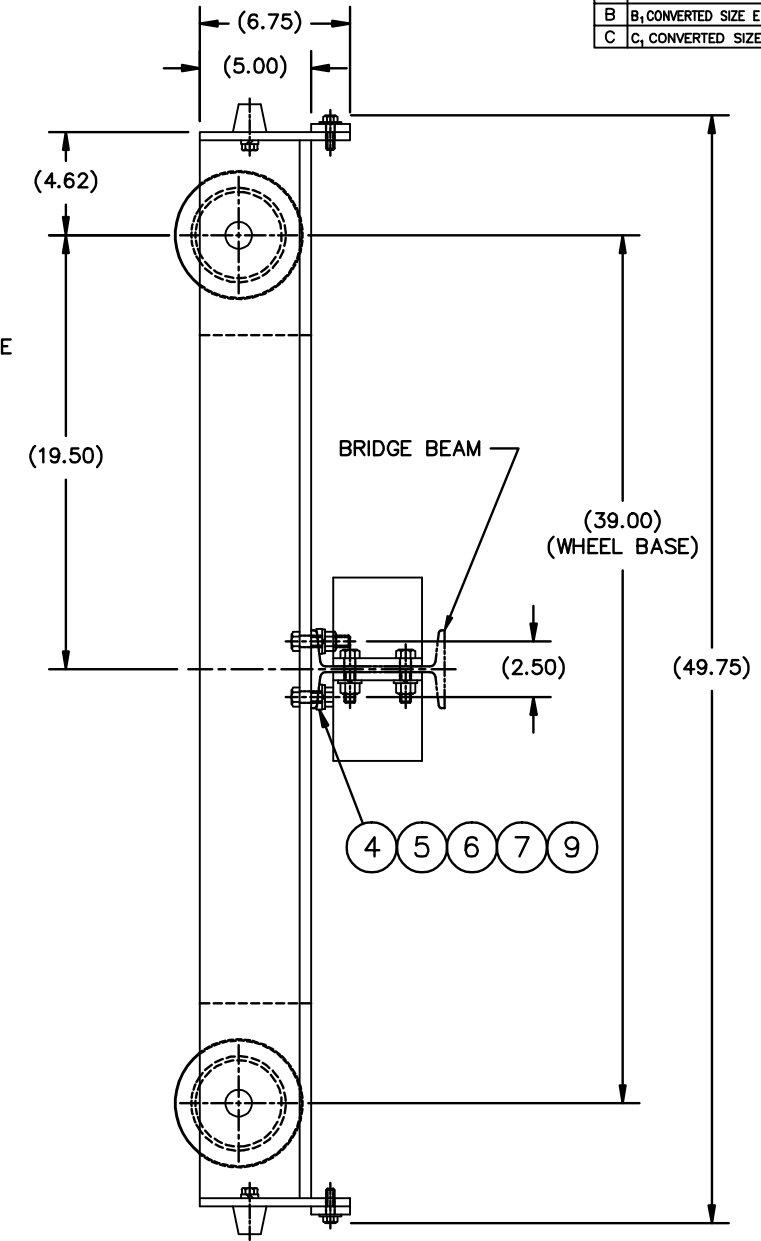
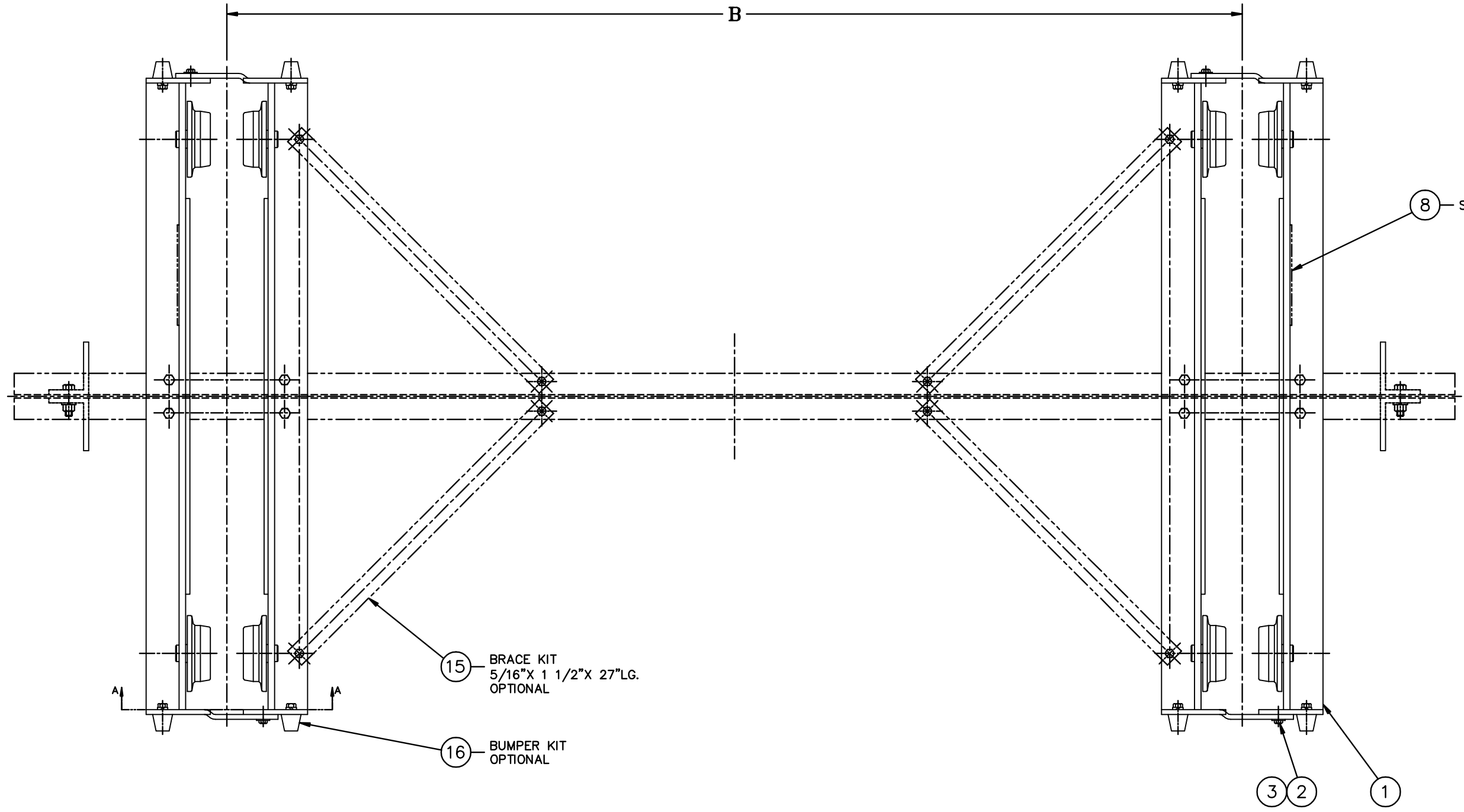

- NOTES:
- TWO COATS OF FAST DRYING SAFETY YELLOW COLOR NO. 13538 OR 1310.
  - CUSTOMER TO SPECIFY CAPACITY DECAL.
  - SUPPLIED IN HARDWARE KIT B-02-05447.
  - BRIDGE CRANES CAN BE RUN ON S AND W-BEAM SHAPES AND ON TOP OF BEAMS.

SEE NOTE #2

47901	2	6,000 POUND DECAL	(3 TON)
44714	2	4,000 POUND DECAL	(2 TON)
44713	2	3,000 POUND DECAL	(1 1/2 TON)
44712	2	2,000 POUND DECAL	(1 TON)
44711	2	1,000 POUND DECAL	(1/2 TON)
44710	2	500 POUND DECAL	(1/4 TON)

17	40840	1	SAFETY STOP KIT	OPTIONAL
16	44601	1	BUMPER KIT	OPTIONAL
15	44596	1	BRACE KIT	OPTIONAL

9	6620-11	8	FLAT WASHER	.546 X 1.203 X #11GA. THK.
8	47948	2	NAMEPLATE	
7	GG 1/2 BEVEL	8	BEVEL WASHER	1/2 BOLT SIZE McMASTER-CARR OR EQ.
6	CDML	8	HEX. HD. SCREW	1/2-13 X 2-1/4 GRADE #5 OR #6
5	CDML	8	LOCK WASHER	1/2 MED.
4	CDML	8	HEX. NUT	1/2-13
3	CDML	4	HEX. HD. SCREW	3/8-16 X 1-1/4 GRADE #5
2	CDML	4	FLAT WASHER	3/8
1	47903	4	SIDE ANGLE ASSEMBLY	

		BEAM CHART (S-BEAMS)											
B SPAN		10.0'	12.5'	15.0'	17.5'	20.0'	22.5'	25.0'	27.5'	30.0'			
LOAD	500#	6 I X 12.5#	6 I X 12.5#	6 I X 12.5#	6 I X 12.5#	6 I X 12.5#	6 I X 12.5#	7 I X 15.3#	7 I X 15.3#	7 I X 20.0#			
	1000#	6 I X 12.5#	7 I X 15.3#	7 I X 15.3#	7 I X 15.3#	7 I X 20.0#	8 I X 18.4#	8 I X 23.0#	10 I X 25.4#	10 I X 25.4#			
	2000#	7 I X 15.3#	8 I X 18.4#	8 I X 23.0#	10 I X 25.4#	10 I X 25.4#	10 I X 35.0#	12 I X 31.8#	12 I X 31.8#	12 I X 35.0#			
	3000#	8 I X 23.0#	10 I X 25.4#	10 I X 35.0#	12 I X 31.8#	12 I X 35.0#	15 I X 42.9#	15 I X 42.9#	15 I X 42.9#	15 I X 42.9#	5.25	S 12.0 X 40.8	
	4000#	10 I X 25.4#	10 I X 35.0#	12 I X 31.8#	15 I X 42.9#	15 I X 42.9#	15 I X 42.9#	15 I X 42.9#	18 I X 54.7#	18 I X 54.7#	5.00	S 12.0 X 31.8	
	6000#	12 I X 31.8#	12 I X 31.8#	12 I X 31.8#	15 I X 42.9#	15 I X 42.9#	15 I X 42.9#	18 I X 54.7#	18 I X 54.7#	18 I X 54.7#	3.33	S 6.0 X 12.5	

MATERIAL: SEE DETAILS

DRINK BY: DJH  
CHECKED BY: PJH  
DESIGNED BY: MRS  
DATE DRAWN: 1/6/94  
CUSTOMER:

GEOMETRY CREATED IN AutoCAD

**CGNYS** Multifaceted & Multifunctional Manufacturing

DESCRIPTION: BRIDGE CRANE ASSEMBLY (WITH FLANGE WHEEL, 3.33 - 5.25 BEAM WIDTH) 3 TON

CODE BENT NO: 52793  
SCALE: 1/4"

DATE: 8/21/06  
PART NUMBER / FILE NAME: 46758

DO NOT SCALE DRAWING

WEIGHT: 300 LBS

REFERENCE: 48498, 44600, 48905, 44525

SHEET 1 of 1 CHARTED