

SEE NOTE 3

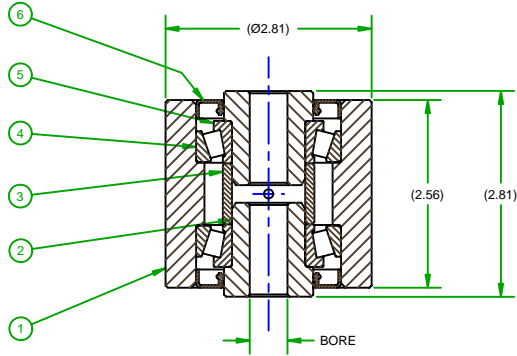

SYM	REVISIONS	DATE	BY	APP.
E	-REMOVED ITEM 7 (WASHER #01-030193), E - ITEM 2 WAS #13-044163, E - UPDATED LUBE SPEC, E - ITEM 6 WAS #13-044166	10/27/04	TPC	MRS
F	WAS 12407, ADDED NOTES 3 & 4	13JUN05	MRS	MRS

- NOTE:
- ① PACK BEARING PER LUBE SPEC 413-13.
 - ② OPTIONAL: CHICAGO RAWHIDE #12428.
 - ③ APPLY FILM OF GREASE TO SEAL LIP BEFORE ASSEMBLY.
 - ④ CHECK BUSHINGS FOR SEAL DRAG. BUSHINGS SHOULD ROTATE BY HAND WITH MINIMUM EFFORT.

QTY	ITEM	DWG	PART OR	NOMENCLATURE OR	CODE	MATERIAL OR NOTE	SPECIFICATION
REQD	NO	SIZE	IDENTIFYING NO.	DESCRIPTION	IDENT		
2	6	~	SE 125-197-25TB	SEAL, NITRILE		ABI INDUSTRIES	
2	5	~	L44643	CONE		TIMKEN OR EQUAL	
2	4	~	L44610	CUP		TIMKEN OR EQUAL	
1	3	B	13-044164	SPACER			
2	2	C	SEE CHART	FLANGE BUSHING			
1	1	C	13-044162	SHELL			

13-044161-4	.765	13-056304-4	3 LB 6 OZ				
13-044161-3	.640	13-056304-3	3 LB 7 OZ				
13-044161-2	.578	13-056304-2	3 LB 9 OZ				
13-044161-1	.515	13-056304-1	3 LB 9 OZ				
PART NO.	BORE	ITEM 2 (FLANGE BUSHING)	WEIGHT	NEXT ASSY	USED ON	QTY	

UNLESS OTHERWISE SPECIFIED DIMENSIONS ARE IN INCHES			DRAWN BY: DJH	<p>ROLLER TURN ROLLER (W/TIMKEN BRG'S)</p> <p>FILE NAME: 44161.dwg</p>
FRACTION	DECIMALS	ANGLES	CHECKED BY: DJH	
$\pm 1/16$	$\pm .005$	$\pm 1^\circ$	ENGR APPROVAL: RCW	
MATERIAL: SEE DETAILS			ORG DATE DRAWN: 4/3/85	<p>CODE IDENT NO. 52793</p> <p>SCALE FULL</p>
FINISH:				<p>13-044161</p> <p>SHEET</p>

C-13-044044, C-13-044157, C-13-044167

CHARTED

13-044161